

## Serie SAS & SAM

## Series SAS & SAM

**Absoluter Drehgeber**  
mit SSI und Sin / Cos Schnittstelle, 58 mm Gehäusedurchmesser,  
bis zu 33 Bit, Single- und Multiturn, Hohl- oder Steckwelle

**Absolute rotary encoder**  
with SSI and sin-cos interface, 58 mm body diameter,  
up to 33 Bits, single- and multiturn, hollow or blind hollow shaft

### Mechanische Daten

Haube / Cover:	Aluminium
Flansch / Body:	Aluminium
Welle / Shaft:	Edelstahl / Stainless steel
Kugellager / Bearings:	doppelt gelagert / 2 ballraces
Gewicht / Weight:	400 g
IP Schutzart / IP protection:	IP64
Umdrehungen / RPM:	max. 6000
Drehmoment / Torque:	< 0.5Ncm
Trägheitsmoment / Inertia:	20gcm <sup>2</sup>
Wellenbelastung / Shaft Load:	Axial 50N – Radial 50N

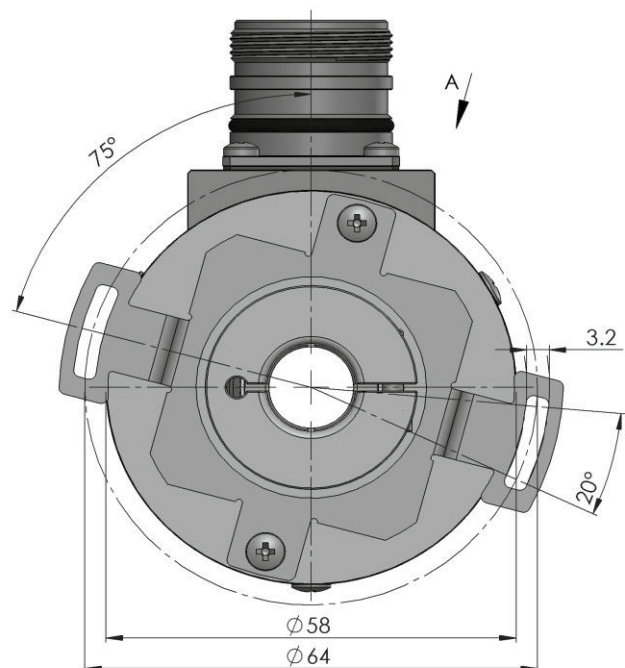
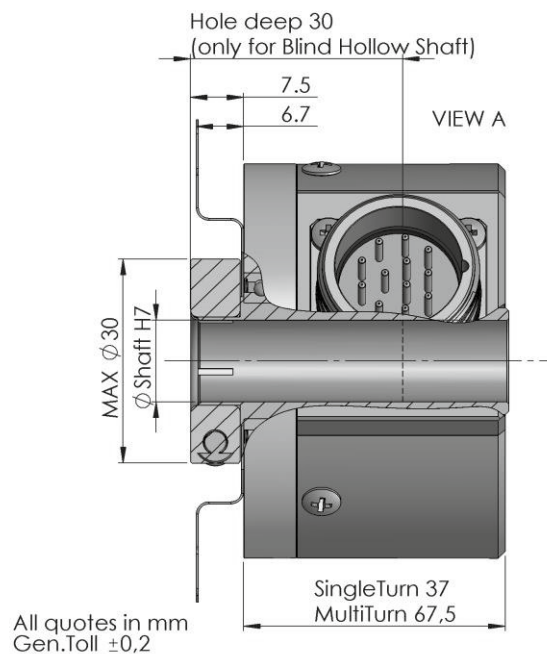

### Elektronische Daten / Electronics Data

Auflösung / Resolution:	ST: Single turn max 17 Bit MT: Multiturn 33 bit (17 Bit ST - 16bit MT)
Versorgungsspannung / Power Supply:	10-28 V +/- 5%
max. Stromaufnahme / Current Cons.:	max. 160 mA
Schnittstelle / Interface:	SSI
Monoflop / Monoflop:	20 usec
Ausgangsdaten / Output Data:	RS422
Codeart / Type of Code:	Binary / Gray
Betriebstemperatur / Operating temperature:	Standard -20° / +80° C

### Bestellbezeichnung / Ordering Code

***	**	*	*	*	*	/	****
Serie / Series	Welle / Shaft	Flansch / Flange	Ausgang / Output	Anschlüsse / Connections	Optionen / Options		BIT
<b>Steckwelle / Blind Hollow Shaft</b>							
SAS = Singleturn  SAM = Multiturn	A = Ø 8 mm B = Ø 10 mm C = Ø 12 mm D = Ø 14 mm E = Ø 15 mm	8	3 = SSI Gray  4 = SSI Binary  5 = SSI Gray + SinCos 2048 1Vpp	<b>Kabel / Cable</b> 9 = Cable Axi 3 = Cable Rad  <b>M23 12p</b> 1 = 9416 Axi CW 2 = 9416 Rad CW 4 = 9416 Axi CCW 5 = 9416 Rad CCW  <b>M12 8p</b> S = 94M12 Axi T = 94M12 Rad	0 = None  5 = 5 Volt  K = Connection K on 9416  Z = Preset (push button)  W = Preset (on cable or connector)		Single Turn  12 13 14 15 16 17  Multi Turn  12 16
<b>Hohlwelle / Hollow Shaft</b>							
SAS = Singleturn	F = Ø 8 mm G = Ø 10 mm H = Ø 12 mm L = Ø 14 mm M = Ø 15 mm	8	3 = SSI Gray  4 = SSI Binary  5 = SSI Gray + SinCos 2048 1Vpp	<b>Kabel / Cable</b> 3 = Cable Rad  <b>M23 12p</b> 2 = 9416 Rad CW 5 = 9416 Rad CCW  <b>M12 8p</b> T = 94M12 Rad	0 = None  5 = 5 Volt  K = Connection K on 9416  Z = Preset (push button)  W = Preset (on cable or connector)		Single Turn  12 13 14 15 16 17

## Anschlüsse / Connections

Kabel Standard Cable Standard	9416 12P Standardanschluss Standard connection	9416 12P Anschluss K Connection K	94M12 8p		
Beige / Beige	1	12	1	0V	0V
Gelb / Yellow	2	3	3	DATA+	Output Data +
Blau / Blue	3	1	5	CLOCK+	Input Clock +
Grün / Green	4	5		A	Channel A (SinCos version)
Schwarz / Black	5	8	8	UP/DOWN	(default: CW increase, to invert connect this pin to 0V)
Rosa / Pink	6	6		B	Channel B (SinCos version)
Grün-Gelb / Green Yellow	7	7		A-	Channel A- (SinCos version)
Braun / Brown	8	11	2	+VCC	+Vcc
Lila / Violet	9	10		B-	Channel B- (SinCos version)
Weiß-Gelb / White-Yellow	10	4	4	DATA-	Output Data -
Weiß-Blau / White-Blue	11	2	6	CLOCK-	Input Clock -
	12	nc	7	GND OUT	Internally connected with Pin 1. (only connection K)
				PRESET	With option W
Kanal A, A/, B, B/ nur mit Ausgang vorhanden / Channel A, /A, B, /B, present only with output					