

A58

PHOTOELECTRIC
ROTARY ENCODER



The A58 series is a photoelectric incremental encoder series that is comprised of 6 iterations – A58M, A58B, A58C, A58C2, A58C3 and A58D. These encoders share the same mechanical and electrical characteristics but differ in mounting options. Encoders produce up

to 108.000 output pulses per revolution and depending on customer demands can have different versions of output signals: 11uApp, 1Vpp, TTL or HTL.

A58M

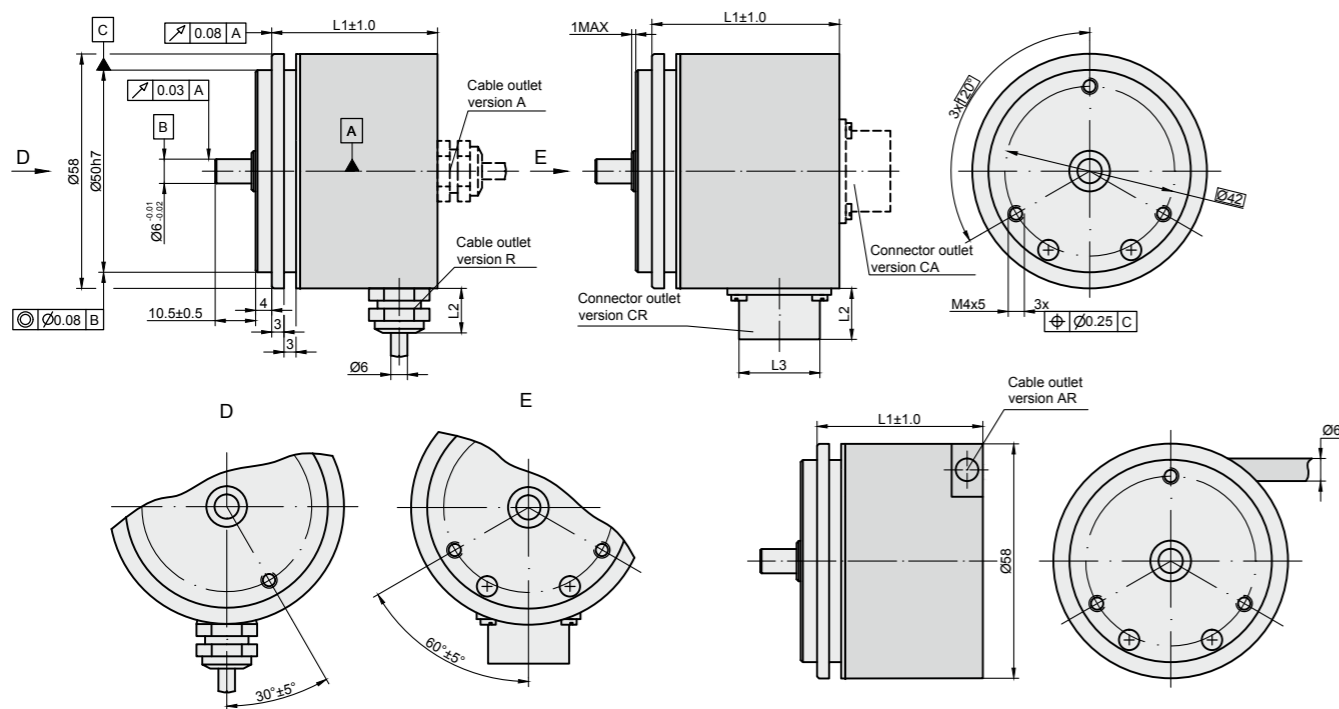

Other mounting versions on pages 27-28

Connector type / cable outlet	ONC axial	RS10 axial	C12, C9 axial	ONC radial	RS10 radial	C12, C9 radial	Cable axial (ver. A)	Cable radial (ver. R)	Cable axial-radial (ver. AR)
L1	41 mm	41 mm	41 mm	54 mm	53 mm	53 mm	41 mm	41 mm	43 mm
L2	16 mm	9 mm	22 mm	16 mm	9 mm	22 mm	12 mm	12 mm	-
L3	M24	M14	M23	M24	M14	M23	-	-	-

MECHANICAL DATA

Line number on disc (z)	100; 250; 500; 600; 800; 1000; 1024; 1125; 1250; 1500; 2000; 2048; 2500; 3000; 3600; 4000; 5000; 9000; 10800	Accuracy (T ₁ -period of lines on disc in arc. sec)	±0.1T ₁ arc. sec
Pulse number per shaft revolution for A58-F	Z x k, where k=1,2,3,4,5,8,10	Starting torque at 20°C	≤ 0.01 Nm
Maximum shaft speed	12000 rpm	Rotor moment of inertia	< 15 gcm ²
Maximum shaft load:		Protection (IEC 529)	IP64
- axial	40 N	Maximum weight without cable	0.25 kg
- radial (at shaft end)	60 N	Operating temperature	-10...+70 °C
		Storage temperature	-30...+80 °C
		Maximum humidity (non-condensing)	98 %
		Permissible vibration (55 to 2000 Hz)	≤ 100 m/s ²
		Permissible shock (11 ms)	≤ 1000 m/s ²

ACCESSORIES

CONNECTORS FOR CABLE	B12 12-pin round connector	C9 9-pin round connector	C12 12-pin round connector	D9 9-pin flat connector	D15 15-pin flat connector	RS10 10-pin round connector	ONC 10-pin round connector
CONNECTORS ON HOUSING	C9 9-pin round connector		C12 12-pin round connector		RS10 10-pin round connector		ONC 10-pin round connector
DIGITAL READOUT DEVICES	CS3000			CS5500			
COUPLING	SC30						
EXTERNAL INTERPOLATOR	NK						

ELECTRICAL DATA

VERSION	A58-A ~ 11 μApp	A58-AV ~ 1 Vpp	A58-F □□ TTL; □□ HTL
Supply voltage (U _p)	+5 V ±5%	+5 V ±5%	+5 V ±5%; +(10 to 30) V
Max. supply current (without load)	80 mA	120 mA	120 mA
Light source	LED	LED	LED
Incremental signals	Two sinusoidal I ₁ and I ₂ Amplitude at 1 kΩ load: - I ₁ = 7-16 μA - I ₂ = 7-16 μA	Differential sine +A/-A and +B/-B Amplitude at 120 Ω load: - A = 0.6-1.2 V - B = 0.6-1.2 V	Differential square-wave U1/U1 and U2/U2. Signal levels at 20 mA load current: - low (logic "0") ≤ 0.5 V at U _p =+5 V - low (logic "0") ≤ 1.5 V at U _p =10 to 30 V - high (logic "1") ≥ 2.4 V at U _p =+5 V - high (logic "1") ≥ (U _p -2) V at U _p =10 to 30 V
Reference signal	One quasi-triangular I ₀ peak per revolution. Signal magnitude at 1 kΩ load: - I ₀ = 2-8 μA (usable component)	One quasi-triangular +R and its complementary -R per revolution. Signals magnitude at 120 Ω load - R = 0.2-0.8 V (usable component)	One differential square-wave U0/U0 per revolution. Signal levels at 20 mA load current: - low (logic "0") < 0.5 V at U _p =+5 V - low (logic "0") < 1.5 V at U _p =10 to 30 V - high (logic "1") > 2.4 V at U _p =+5 V - high (logic "1") > (U _p -2) V at U _p =10 to 30 V
Maximum operating frequency	(-3 dB) ≥ 160 kHz	(-3 dB) ≥ 180 kHz	(160 x k) kHz, k-interpolation factor
Direction of signals	I ₂ lags I ₁ for clockwise rotation (viewed from shaft side)	+B lags +A for clockwise rotation (viewed from shaft side)	U2 lags U1 with clockwise rotation (viewed from shaft side)
Maximum rise and fall time	-	-	< 0.5 μs
Standard cable length	1 m, without connector	1 m, without connector	1 m, without connector
Maximum cable length	5 m	25 m	25 m
Output signals			

Note:

- Maximum working rotation speed (with proper encoder counting) is limited by maximum operating frequency and maximum mechanical rotation speed.
- If cable extension is used, power supply conductor cross-section should not be smaller than 0.5 mm².