

A110

PHOTOELECTRIC ANGLE ENCODER

Photoelectric angle encoder A110 is a similar high end encoder to A90H, but with a solid shaft. It is able to produce up to 1.800.000 output pulses per revolution and can have a modification with a distance-coded reference mark.

- Analog output signals
- High Resolutions
- Hollow Shaft
- Distance Coded reference mark
- High precision

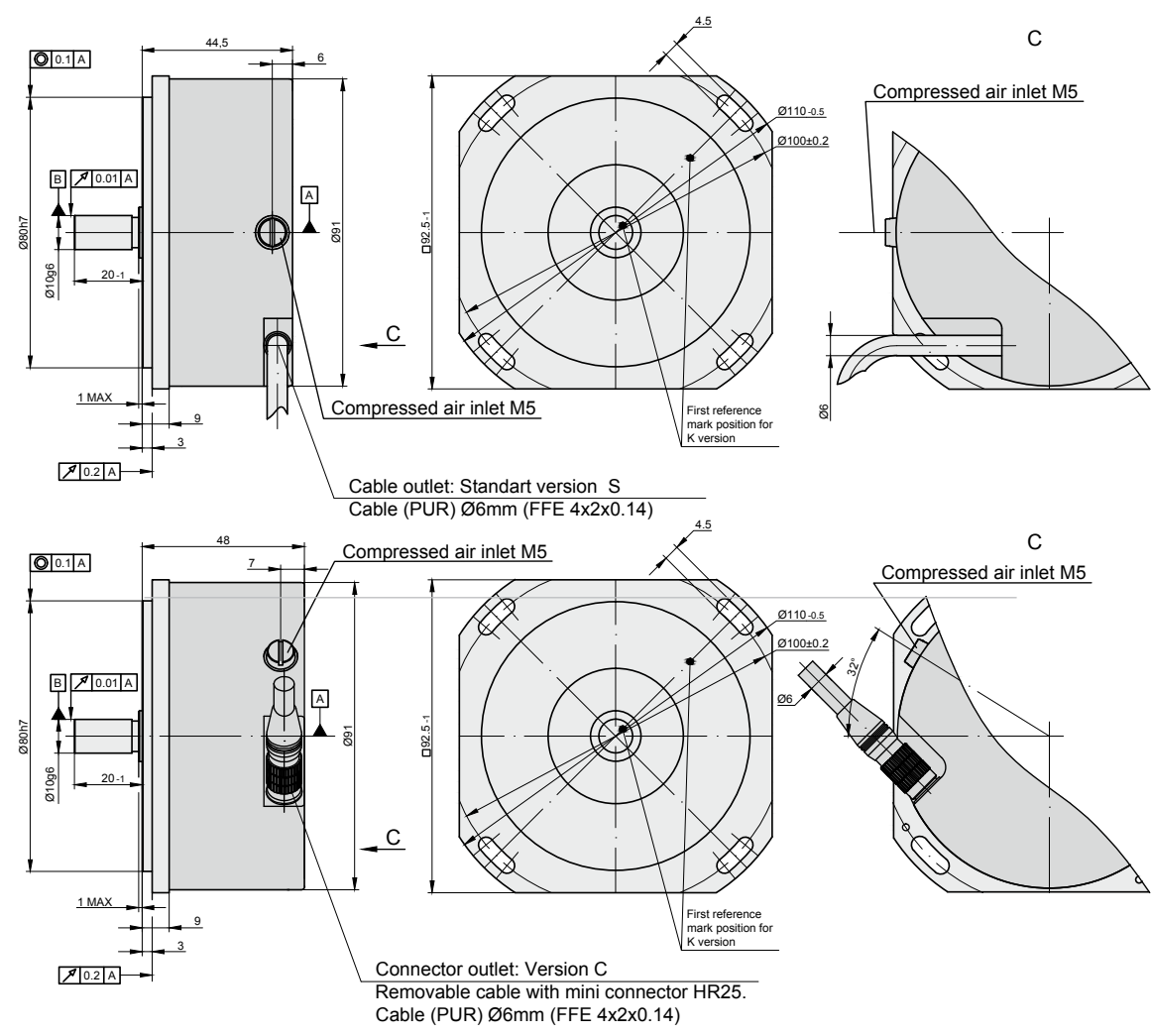

MECHANICAL DATA

Line number on disc (z)	18000	Accuracy	±5.0 arc. sec
Number of output pulses per revolution for A110-F	Z x k, where k = 1, 2, 3, 4, 5, 8, 10, 20, 25, 50, 100.	Starting torque at 20°C	≤ 0.01Nm
Reference signal:		Rotor moment of inertia	< 20×10 ⁻⁶ kgm ²
- standard (S)	one per shaft revolution	Protection (IEC 529)	IP64
- distance-coded (K)	36 per shaft revolution	Maximum weight without cable	0.7 kg
Maximum shaft speed	5000 rpm	Operating temperature	0...+50 °C
		Storage temperature	-30...+80°C
		Maximum humidity (non condensing)	98 %
Maximum shaft load:		Permissible vibration	≤ 100 m/s ²
- axial	10 N	Permissible shock (6 ms)	≤ 300 m/s ²
- radial (at shaft end)	10 N		

ELECTRICAL DATA

VERSION	A110-A ~ 11 µApp	A110-AV ~ 1 Vpp	A110-F TTL
Supply voltage (U _p)	+5 V ± 5%	+5 V ± 5%	+5 V ± 5%;
Max. supply current (without load)	80 mA	120 mA	120 mA
Light source	LED	LED	LED
Incremental signals	Two sinusoidal I ₁ and I ₂ Amplitude at 1 kΩ load: - I ₁ = 7-16 µA - I ₂ = 7-16 µA	Differential sine +A/-A and +B/-B Amplitude at 120 Ω load: - A = 0.6-1.2 V - B = 0.6-1.2 V	Differential square-wave U1/Ū1 and U2/Ū2. Signal levels at 20 mA load current: - low (logic "0") ≤ 0.5 V - high (logic "1") ≥ 2.4 V
Reference signal	One quasi-triangular I ₀ peak per revolution. Signal magnitude at 1 kΩ load: - I ₀ = 2-8 µA (usable component)	One quasi-triangular +R and its complementary -R per revolution. Signals magnitude at 120Ω load - R = 2-8 V (usable component)	One differential square-wave U0/Ū0 per revolution. Signal levels at 20 mA load current: - low (logic "0") < 0.5 V - high (logic "1") > 2.4 V
Fault detection signal Ūs	- - no error occur - error occur	one square-wave pulse high low	one square-wave pulse high low
Maximum operating frequency	(-3 dB) ≥ 160 kHz	(-3 dB) ≥ 180 kHz	(160 x k) kHz, k-interpolation factor
Direction of signals	I ₂ lags I ₁ for clockwise rotation (viewed from shaft side)	+B lags +A for clockwise rotation (viewed from shaft side)	U2 lags U1 with clockwise rotation (viewed from shaft side)
Maximum rise and fall time	-	-	< 0.5 µs
Standard cable length	1 m, without connector	1 m, without connector	1 m, without connector
Maximum cable length	5 m	25 m	25 m
Output signals			

Note:

- Maximum working rotation speed (with proper encoder counting) is limited by maximum operating frequency and maximum mechanical rotation speed.
- If cable extension is used, power supply conductor cross-section should not be smaller than 0.5 mm².

ACCESSORIES

CONNECTORS FOR CABLE	B12 12-pin round connector	C9 9-pin round connector	C12 12-pin round connector	D9 9-pin flat connector	D15 15-pin flat connector	RS10 10-pin round connector	ONC 10-pin round connector
DIGITAL READOUT DEVICES	CS3000				CS5500		
COUPLING	SC70						
EXTERNAL INTERPOLATOR	NK						

ORDER FORM

A110 - X - XXXXXXX - X - X - XXX - X

OUTPUT SIGNAL VERSION:	PULSE NUMBER PER REVOLUTION:	REFERENCE SIGNAL:	CABLE OR CONNECTOR OUTLET:	CABLE LENGTH:	CONNECTOR TYPE:	COUPLING:
A	1...18000	S - one per revolution	S - version S (cable outlet)	AR01 - 1m	W - without connector	0 - without coupling
AV	...	K - 36 per revolution, distance-coded	C-version C (connector outlet)	AR02 - 2m	B12 - round, 12 pins	1 - with coupling
F	1...1800000			AR03 - 3m	C9 - round, 9 pins	
				C12 - round, 12 pins	
					D9 - flat, 9 pins	
					D15 - flat, 15 pins	
					RS10 - round, 10 pins	
					ONC - round, 10 pins	

ORDER EXAMPLE: 1) A110-F-18000-K-S-AR02/C12-0